

# Industrial Baymaster™ HL LED Luminaire

## High Bay for Ordinary Locations

**NEC/CEC:**  
 Marine outside type (salt water) for USA Only  
 Wet locations  
 Type 3R, 4, 4X  
 IP66/67

### Applications

- Powerful, efficient weatherproof lighting for applications such as:
  - Warehouses
  - Waste water treatment facilities
  - Production facilities
  - Processing plants
  - Storage areas
- Locations requiring IP66/67, Type 4X, marine and wet location.
- Locations requiring dependable, consistent lighting in extreme hot/cold temperature environments.

### Features

- Three lumen outputs provide up to 38,000 lumens.

Nominal Lumens ①	Wattage (W)	Efficacy (lpw)	HID Equivalent	Model Number
24,000	180	133	1000W	IBHLL1/IBHLPL1
30,000	225	133	1000-1500W	IBHLL2/IBHLPL1
38,000	310	123	1500W	IBHLL3/IBHLPL1

① Nominal lumen value for 5000K, detailed lumen information provided in tables.



High Bay

- Choice of optics for optimal light distribution in a variety of applications; narrow, medium and wide distribution.
- Unique quick mount pendant system allows for easy prewiring without supporting the High Bay in place. Quick mount adapter hood includes one 3/4" NPT entry.
- Alternate mounting system allows for "Y" cable mount and easy wiring via a separate field wiring compartment with a screw terminal block (can accept UL/CSA 26-10AWG).
- Two 3/4" NPT entries provided. (Two close up plugs provided when quick mount pendant system is ordered).
- One 1/2" NPT close up plug provided on quickmount model for use with accessory drain assembly.
- Choice of color temperature (CCT); 5000K cool white or 3000K warm white.
- Rugged and compact housing with superior thermal design translates to long luminaire life.
- Ambient Temperature: -40 °C to +65 °C (-40 °F to +149 °F)
- Heavy duty, high temperature silicone rubber gaskets.
- Thermal shock and impact resistant clear or frosted glass lens.
- Choice of Input Voltages:
  - 120-277 Vac 50/60 Hz, 170-300 Vdc
  - 347-480 Vac 50/60 Hz
- Standard 6kV surge protection.
- Captive fasteners secure one piece lens.
- Field replaceable LED driver and lens cover.

### Options

- Improved safety cable design with multiple retention points, purchase separately
- Guard available, purchase separately
- 10kV Surge Protection
- Y mount cable assembly, purchase separately
- Drain assembly, purchased separately

### Standard Materials

- Housing and lens door: copperfree (4/10 of 1% max.) aluminum
- Gaskets: silicone rubber
- Quick mount hood and body: copperfree (4/10 of 1% max.) aluminum
- Exterior hardware: stainless steel
- Close up plugs: (two 3/4", one 1/2") aluminum provided for quick mount, (one 3/4") aluminum provided otherwise
- Guard and safety cable: stainless steel

### Standard Finishes

- Housing, lens cover, quick mount body and hood; baked gray epoxy powder coat finish, electrostatically applied for complete uniform protection

### Related Products

- See Industrial Baymaster™ LED for locations requiring lumen outputs of 9.5K, 15K and 19.5K
- See Baymaster™ LED for Class I, Division 2 hazardous locations requiring lumen outputs of 9.5K, 15K and 19.5K
- See Baymaster™ HL LED for Class I, Division 2 hazardous locations requiring higher lumen outputs of 24K, 30K and 38K

LED/HIGH BAY- NEC/CEC ORDINARY LOCATION

Appleton

# Industrial Baymaster™ HL LED Luminaire

## High Bay for Ordinary Locations

NEC/CEC:  
 Marine outside type (salt water) for USA Only  
 Wet locations  
 Type 3R, 4, 4X  
 IP66/67

LED/AREA/NEC/CEC/EXPLOSIONPROOF/ATEX/IECEx/FLAMEPROOF/INCREASED SAFETY

### Illustrated Features

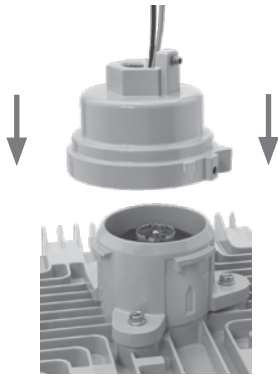

#### Quick Mount Pendant System

Appleton's patented quick mount pendant system allows for easy prewiring of a hood for quick, one person fixture installation. Simply align the arrows, push up, and rotate the luminaire a quarter turn until it locks into place. Specify quick mount pendant with a "P" in the fifth digit of the part number.



#### Cable Mount Option

The Baymaster High Bay can also be mounted with two Y style aircraft cables with spring clips, secured to eye bolts on the luminaire housing. Non quick mount models can be cable mounted and are wired through the 3/4" NPT entries in the wire box.



#### Driver Assembly

Replaceable drivers are waterproof (IP67) and offer standard 6KV surge protection and over temperature protection.

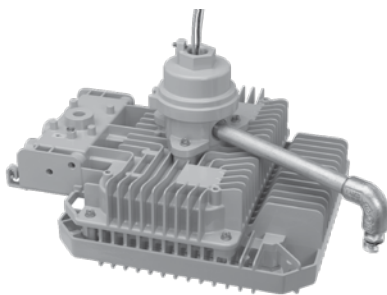

#### Optional Drain Assembly

Includes 9" long, 1/2" trade size conduit nipple, elbow and drain.

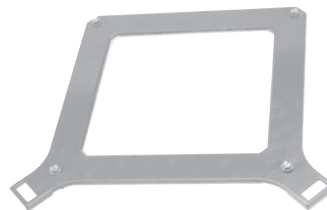

#### Replaceable Cover Assembly

The replaceable cover assembly is available with clear or frosted glass.

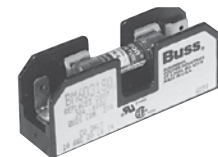

#### Optional Fusing \*

Luminaire can be ordered with optional fusing. Fusing is not field installable.  
 \* Use of fuse voids marine rating.

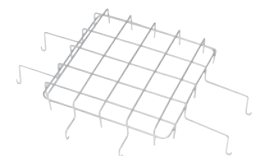

#### Optional Wire Guard

Stainless steel wire guard can be used for additional protection.

Appleton

# Industrial Baymaster™ HL LED Luminaire

## High Bay for Ordinary Locations

**NEC/CEC:**  
 Marine outside type (salt water) for USA Only  
 Wet locations  
 Type 3R, 4, 4X  
 IP66/67

### NEC/CEC Certifications and Compliances

- UL Standards:
  - UL1598, Luminaires
  - UL1598A, Luminaires for Installation on Marine Vessels
  - UL 8750, LED Equipment for Use in Lighting Products
- CSA Standards:
  - CSA C22.2 No. 250.0, Luminaires
- cCSAus: 164460 Certificate Number: 70073608

### DesignLights™ Consortium (for the following models)

- All models

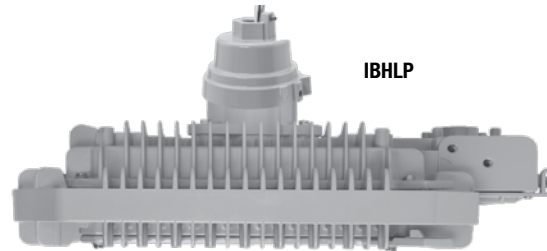
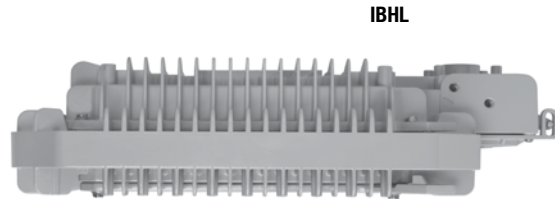

Order using catalog numbering guides below or select catalog number from tables on following pages.

<b>IBHL</b>	<b>P</b>	<b>L1</b>	<b>C</b>	<b>G</b>	<b>M</b>	<b>N</b>	<b>BU</b>	<b>S</b>
Series: IBHL: Baymaster HL LED Series	Mounting ①: P - Quick Mount Pendant Blank - No Quick Mount	Lumen Level: L1 - 24K L2 - 30K L3 - 38K	Color Temp CCT: C - 5000K W - 3000K ②	Diffusion: G - Clear Glass F - Frosted Glass ③	M - Medium W - Wide N - Narrow	Dimming: N - None	Voltage: BU = 120V-277Vac 50/60 Hz, 170-300Vdc BH = 347-480Vac 50/60 Hz	Options: F - Fusing ④ S - 10kV Surge Protection

### Lumen Output Tables ⑤:

Lumen Output for Clear Glass Lens			
	IBHLL1/IBHLPL1	IBHLL2/IBHLPL2	IBHLL3/IBHLPL3
Type V Medium (Non Optic), 5000K CCT, CRI 70	24,400	30,400	37,600
Type V Wide 3000K CCT, CRI 80	18,700	22,300	28,900
Type V Wide 5000K CCT, CRI 70	20,700	25,900	33,400
Type V Narrow 3000K CCT, CRI 80	21,600	25,800	33,300
Type V Narrow 5000K CCT, CRI 70	24,500	30,400	39,000

Lumen Output for Frosted Glass Lens			
	IBHLL1/IBHLPL1	IBHLL2/IBHLPL2	IBHLL3/IBHLPL3
Type V (Non Optic), 5000K CCT, CRI 70	20,800	26,000	32,100

① Quick mount pendant includes pre wired, factory installed, quick mount pendant body and hood. No quick mount models are wired through the 3/4" NPT entries and a provided screw terminal block in the wiring compartment.

② 3000K CCT (Warm) is only available with Type V Wide or Narrow light patterns

③ Frosted Glass is only available with Type V Medium light pattern

④ Use of fuse voids Marine rating.

⑤ All lumen values are typical (tolerance +/-10%).

LED/HIGH BAY: NEC/CEC ORDINARY LOCATION



# Industrial Baymaster™ HL LED Luminaire

## High Bay for Ordinary Locations

**NEC/CEC:**  
*Marine outside type (salt water) for USA Only*  
**Wet locations**  
*Type 3R, 4, 4X*  
**IP66/67**

### Electrical Ratings ①

Model Number	Voltage Suffix	Voltage (V)	Input Power (Watts)	Input Current (Amps)	Power Factor (PF)	Total Harmonic Distortion (THD)
IBHLL1 IBHLPL1	BU	120 Vac	180	1.52	>.9	<20%
		277 Vac	176	0.67		
		170 Vdc	172	1.02	N/A	N/A
		300 Vdc	170	0.57		
BH	347 Vac	179	0.52	>.9	<20%	
	480 Vac	179	0.39			
IBHLL2 IBHLPL2	BU	120 Vac	231	1.94	>.9	<20%
		277 Vac	231	0.88		
		170 Vdc	220	1.30	N/A	N/A
		300 Vdc	217	0.72		
BH	347 Vac	219	0.64	>.9	<20%	
	480 Vac	219	0.47			
IBHLL3 IBHLPL3	BU	120 Vac	317	2.67	>.9	<20%
		277 Vac	303	1.15		
		170 Vdc	305	1.80	N/A	N/A
		300 Vdc	298	0.99		
BH	347 Vac	299	0.87	>.9	<20%	
	480 Vac	298	0.63			

### Ambient Temperature Range:

- IBHLL1, IBHLPL1: -40 °C to +65 °C (-40 °C to +149 °F)
- IBHLL2, IBHLPL2: -40 °C to +65 °C (-40 °C to +149 °F)
- IBHLL3, IBHLPL3: -40 °C to +55 °C (-40 °C to +131 °F)

Surge Protection: Integral 6KV surge protection. Option for up to 10KV surge protection. (cCSAus only).

① All ratings are typical.

LED/HIGH BAY: NEC/CEC ORDINARY LOCATION

Appleton®

# Industrial Baymaster™ HL LED Luminaire

## High Bay for Ordinary Locations

**NEC/CEC:**

Marine outside type (salt water) for USA Only

Wet locations

Type 3R, 4, 4X

IP66/67

CCT	Lumen Output	Wattage	Efficacy (lm/W)	Optical Pattern	Catalog Number ①
<b>Clear Glass With Quick Mount Pendant System</b>					
<b>120-277 Vac/170-300 Vdc</b>					
5000K (cool white)	24400	177	138	Type V Medium (120° beam angle)	IBHLPL1CGMNBU
5000K (cool white)	20700	177	117	Type V Wide (140° beam angle)	IBHLPL1CGWNBU
5000K (cool white)	24500	177	138	Type V Narrow (80° beam angle)	IBHLPL1CGNNBU
3000K (warm white)	18700	177	106	Type V Wide (140° beam angle)	IBHLPL1WGWNBU
3000K (warm white)	21600	177	122	Type V Narrow (80° beam angle)	IBHLPL1WGNNBU
5000K (cool white)	30400	227	134	Type V Medium (120° beam angle)	IBHLPL2CGMNBU
5000K (cool white)	25900	227	114	Type V Wide (140° beam angle)	IBHLPL2CGWNBU
5000K (cool white)	30400	227	134	Type V Narrow (80° beam angle)	IBHLPL2CGNNBU
3000K (warm white)	22300	215	104	Type V Wide (140° beam angle)	IBHLPL2WGWNBU
3000K (warm white)	25800	215	120	Type V Narrow (80° beam angle)	IBHLPL2WGNNBU
5000K (cool white)	37600	308	122	Type V Medium (120° beam angle)	IBHLPL3CGMNBU
5000K (cool white)	33400	308	108	Type V Wide (140° beam angle)	IBHLPL3CGWNBU
5000K (cool white)	39000	308	127	Type V Narrow (80° beam angle)	IBHLPL3CGNNBU
3000K (warm white)	28900	295	98	Type V Wide (140° beam angle)	IBHLPL3WGWNBU
3000K (warm white)	33300	295	113	Type V Narrow (80° beam angle)	IBHLPL3WGNNBU
<b>347-480 Vac</b>					
5000K (cool white)	24400	177	138	Type V Medium (120° beam angle)	IBHLPL1CGMNBH
5000K (cool white)	20700	177	117	Type V Wide (140° beam angle)	IBHLPL1CGWNBH
5000K (cool white)	24500	177	138	Type V Narrow (80° beam angle)	IBHLPL1CGNNBH
3000K (warm white)	18700	177	106	Type V Wide (140° beam angle)	IBHLPL1WGWNBH
3000K (warm white)	21600	177	122	Type V Narrow (80° beam angle)	IBHLPL1WGNNBH
5000K (cool white)	30400	227	134	Type V Medium (120° beam angle)	IBHLPL2CGMNBH
5000K (cool white)	25900	227	114	Type V Wide (140° beam angle)	IBHLPL2CGWNBH
5000K (cool white)	30400	227	134	Type V Narrow (80° beam angle)	IBHLPL2CGNNBH
3000K (warm white)	22300	215	104	Type V Wide (140° beam angle)	IBHLPL2WGWNBH
3000K (warm white)	25800	215	120	Type V Narrow (80° beam angle)	IBHLPL2WGNNBH
5000K (cool white)	37600	308	122	Type V Medium (120° beam angle)	IBHLPL3CGMNBH
5000K (cool white)	33400	308	108	Type V Wide (140° beam angle)	IBHLPL3CGWNBH
5000K (cool white)	39000	308	127	Type V Narrow (80° beam angle)	IBHLPL3CGNNBH
3000K (warm white)	28900	295	98	Type V Wide (140° beam angle)	IBHLPL3WGWNBH
3000K (warm white)	33300	295	113	Type V Narrow (80° beam angle)	IBHLPL3WGNNBH
<b>Frosted Glass With Quick Mount Pendant System</b>					
<b>120-277 Vac/170-300 Vdc</b>					
5000K (cool white)	20800	177	118	Type V Medium (120° beam angle)	IBHLPL1CFMNBH
5000K (cool white)	26000	227	115	Type V Medium (120° beam angle)	IBHLPL2CFMNBH
5000K (cool white)	32100	305	105	Type V Medium (120° beam angle)	IBHLPL3CFMNBH
<b>347-480 Vac</b>					
5000K (cool white)	20800	177	118	Type V Medium (120° beam angle)	IBHLPL1CFMNBH
5000K (cool white)	26000	227	115	Type V Medium (120° beam angle)	IBHLPL2CFMNBH
5000K (cool white)	32100	305	105	Type V Medium (120° beam angle)	IBHLPL3CFMNBH



LED/HIGH BAY- NEC/CEC ORDINARY LOCATION





Appleton®

① For Fusing option, add suffix **F** to end of part number, example IBHLPL2CGMNBUF.  
 For 10KV surge protection, add suffix **S** to end of part number, example IBHLPL1CGMNBUS.  
 For both Fusing and 10KV surge, add suffix **FS** to end of part number, example IBHLPL1CGMNBUSFS.

# Industrial Baymaster™ HL LED Luminaire

## High Bay for Ordinary Locations

NEC/CEC:  
 Marine outside type (salt water) for USA Only  
 Wet locations  
 Type 3R, 4, 4X  
 IP66/67

	CCT	Lumen Output	Wattage	Efficacy (lm/W)	Optical Pattern	Catalog Number ①
<b>Clear Glass Without Quick Mount Pendant System</b>						
<b>120-277 Vac/170-300 Vdc</b>						
	5000K (cool white)	24400	177	138	Type V Medium (120° beam angle)	IBHLL1CGMNBUS
	5000K (cool white)	20700	177	117	Type V Wide (140° beam angle)	IBHLL1CGWNBUS
	5000K (cool white)	24500	177	138	Type V Narrow (80° beam angle)	IBHLL1CGNNBUS
	3000K (warm white)	18700	177	106	Type V Wide (140° beam angle)	IBHLL1WGWNBUS
	3000K (warm white)	21600	177	122	Type V Narrow (80° beam angle)	IBHLL1WGNNBUS
	5000K (cool white)	30400	227	134	Type V Medium (120° beam angle)	IBHLL2CGMNBUS
	5000K (cool white)	25900	227	114	Type V Wide (140° beam angle)	IBHLL2CGWNBUS
	5000K (cool white)	30400	227	134	Type V Narrow (80° beam angle)	IBHLL2CGNNBUS
	3000K (warm white)	22300	215	104	Type V Wide (140° beam angle)	IBHLL2WGWNBUS
	3000K (warm white)	25800	215	120	Type V Narrow (80° beam angle)	IBHLL2WGNNBUS
	5000K (cool white)	37600	308	122	Type V Medium (120° beam angle)	IBHLL3CGMNBUS
	5000K (cool white)	33400	308	108	Type V Wide (140° beam angle)	IBHLL3CGWNBUS
	5000K (cool white)	39000	308	127	Type V Narrow (80° beam angle)	IBHLL3CGNNBUS
	3000K (warm white)	28900	295	98	Type V Wide (140° beam angle)	IBHLL3WGWNBUS
	3000K (warm white)	33300	295	113	Type V Narrow (80° beam angle)	IBHLL3WGNNBUS
<b>347-480 Vac</b>						
	5000K (cool white)	24400	177	138	Type V Medium (120° beam angle)	IBHLL1CGMNBH
	5000K (cool white)	20700	177	117	Type V Wide (140° beam angle)	IBHLL1CGWNBH
	5000K (cool white)	24500	177	138	Type V Narrow (80° beam angle)	IBHLL1CGNNBH
	3000K (warm white)	18700	177	106	Type V Wide (140° beam angle)	IBHLL1WGWNBH
	3000K (warm white)	21600	177	122	Type V Narrow (80° beam angle)	IBHLL1WGNNBH
	5000K (cool white)	30400	227	134	Type V Medium (120° beam angle)	IBHLL2CGMNBH
	5000K (cool white)	25900	227	114	Type V Wide (140° beam angle)	IBHLL2CGWNBH
	5000K (cool white)	30400	227	134	Type V Narrow (80° beam angle)	IBHLL2CGNNBH
	3000K (warm white)	22300	215	104	Type V Wide (140° beam angle)	IBHLL2WGWNBH
	3000K (warm white)	25800	215	120	Type V Narrow (80° beam angle)	IBHLL2WGNNBH
	5000K (cool white)	37600	308	122	Type V Medium (120° beam angle)	IBHLL3CGMNBH
	5000K (cool white)	33400	308	108	Type V Wide (140° beam angle)	IBHLL3CGWNBH
	5000K (cool white)	39000	308	127	Type V Narrow (80° beam angle)	IBHLL3CGNNBH
	3000K (warm white)	28900	295	98	Type V Wide (140° beam angle)	IBHLL3WGWNBH
	3000K (warm white)	33300	295	113	Type V Narrow (80° beam angle)	IBHLL3WGNNBH
<b>Frosted Glass Without Quick Mount Pendant System</b>						
<b>120-277 Vac/170-300 Vdc</b>						
	5000K (cool white)	20800	177	118	Type V Medium (120° beam angle)	IBHLL1CFMNBUS
	5000K (cool white)	26000	227	115	Type V Medium (120° beam angle)	IBHLL2CFMNBUS
	5000K (cool white)	32100	305	105	Type V Medium (120° beam angle)	IBHLL3CFMNBUS
<b>347-480 Vac</b>						
	5000K (cool white)	20800	177	118	Type V Medium (120° beam angle)	IBHLL1CFMNBH
	5000K (cool white)	26000	227	115	Type V Medium (120° beam angle)	IBHLL2CFMNBH
	5000K (cool white)	32100	305	105	Type V Medium (120° beam angle)	IBHLL3CFMNBH

① For Fusing option, add suffix **F** to end of part number, example IBHLPL2CGMNBUSF.  
 For 10KV surge protection, add suffix **S** to end of part number, example IBHLPL1CGMNBUS.  
 For both Fusing and 10KV surge, add suffix **FS** to end of part number, example IBHLPL1CGMNBUSFS.

LED/HIGH BAY: NEC/CEC ORDINARY LOCATION



# Industrial Baymaster™ HL LED Luminaire

## High Bay for Ordinary Locations

**NEC/CEC:**





Marine outside type (salt water) for USA Only

Wet locations

Type 3R, 4, 4X

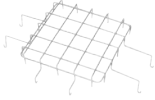
IP66/67

### Accessories and Replacement Parts

	Description	Catalog Number
<b>Wire Guard</b>		
	Stainless steel.	LHGUARD
<b>Safety Cable</b>		
	Stainless steel.	LEDSC
<b>Drain</b>		
	9" long, 1/2" trade size drain assembly for use with quick mount pendant hood.	LEDDR9
<b>Y Mounting Cable</b>		
	1.5 M (5 ft.) cable mount - stainless steel. Includes two (5 ft.) Y cables with spring clips and four eye bolts.	LEDC5
<b>Safety Support Hooks</b>		
	3/4" malleable iron hook and loop	EFHM-75

LED/HIGH BAY- NEC/CEC ORDINARY LOCATION

Appleton®

# Industrial Baymaster™ HL LED Luminaire

## High Bay for Ordinary Locations

**NEC/CEC:**

Marine outside type (salt water) for USA Only

Wet locations

Type 3R, 4, 4X

IP66/67

Description	Catalog Number
-------------	----------------

**Replacement Covers**



Clear Replacement Cover

**BHLCLEAR**

Frosted Replacement Cover

**BHLFROST**

Voltage	Driver Wattage	Constant Current Setting	Luminaire Model	CCT	Catalog Number
---------	----------------	--------------------------	-----------------	-----	----------------

**Replacement Drivers**



BU

150 watt

915mA

IBHLL3C/  
IBHLPL3C

5000K

**APMS150C105UD91**

BH

**APMS150C105HD91**

BU

150 watt

680mA

IBHLL2C/  
IBHLPL2C

5000K

**APMS150C105U68**

BH

**APMS150C105HD68**

BU

150 watt

890mA

IBHLL3W/  
IBHLPL3W

3000K

**APMS150C105UD89**

BH

**APMS150C105HD89**



BU

150 watt

650mA

IBHLL2W/  
IBHLPL2W

3000K

**APMS150C105UD65**

BH

**APMS150C105HD65**

BU

100 watt

530mA

IBHLL1C/  
IBHLPL1C  
IBHLL1W/  
IBHLPL1W

5000K and  
3000K

**APMS100C105UD53**

BH

**APMS100C105HD53**

**Industrial Baymaster Accessory Weights**

Description	Weight in kg (lbs)
IBHLL1/IBHLPL1, IBHLL2/IBHLPL2, IBHLL3/IBHLPL3 Luminaires	16.1 (35.4)
Quick Mount Hood	0.6 (1.4)
Guard	0.2 (0.4)
Safety Cable	0.2 (0.4)
Drain	0.5 (1.2)
Y Cable Mount	0.5 (1.2)

LED/HIGH BAY: NEC/CEC ORDINARY LOCATION



# Industrial Baymaster™ HL LED Luminaire

## High Bay for Ordinary Locations

NEC/CEC:  
 Marine outside type (salt water) for USA Only  
 Wet locations  
 Type 3R, 4, 4X  
 IP66/67

Dimensions in Millimeters (Inches)

### High Bay – With Quick Mount Pendant System

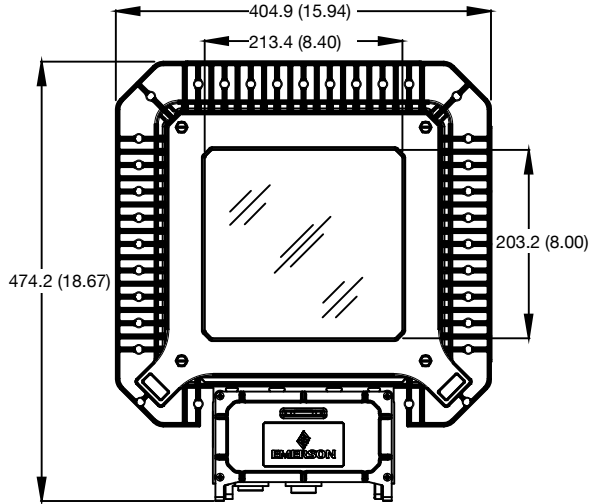

Front View

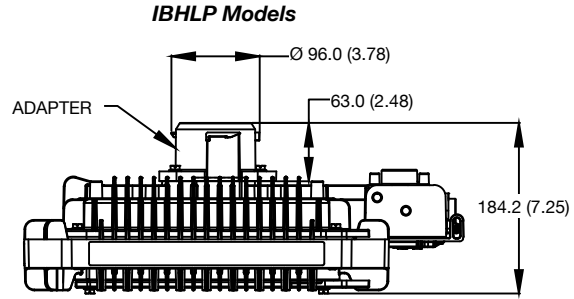

Side View

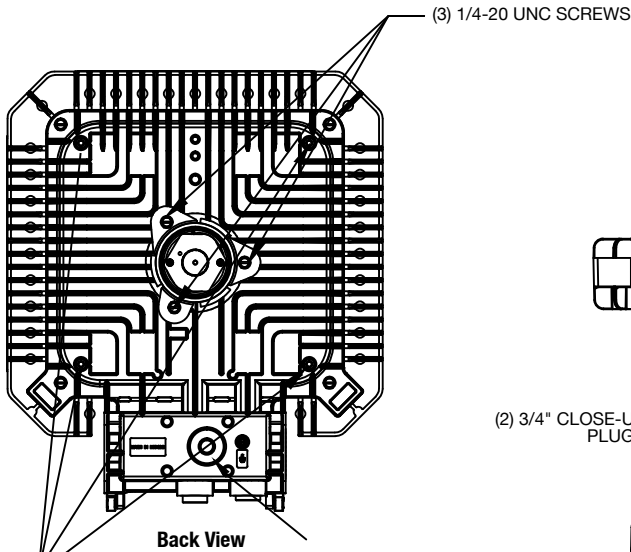

Back View

(4) 1/4-20 THREADS FOR Y  
 CABLE ASSEMBLY EYE BOLTS

(1) 3/4 - 14 NPT  
 FOR CABLE ENTRY WITH  
 CLOSE-UP PLUG

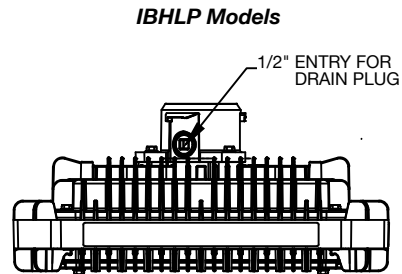

Top View

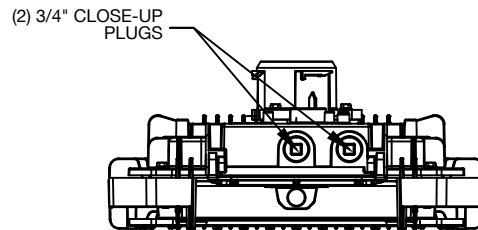

Bottom View

LED/HIGH BAY- NEC/CEC ORDINARY LOCATION



# Industrial Baymaster™ HL LED Luminaire

## High Bay for Ordinary Locations

NEC/CEC:  
 Marine outside type (salt water) for USA Only  
 Wet locations  
 Type 3R, 4, 4X  
 IP66/67

Dimensions in Millimeters (Inches)

High Bay – No Mount

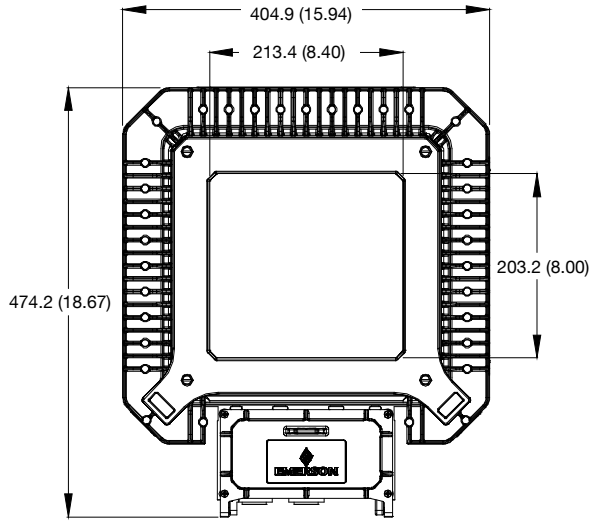

Front View

IBHL Models

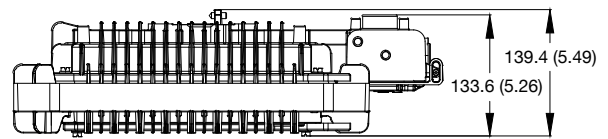

Side View

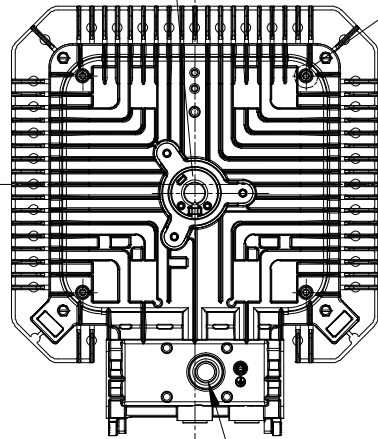
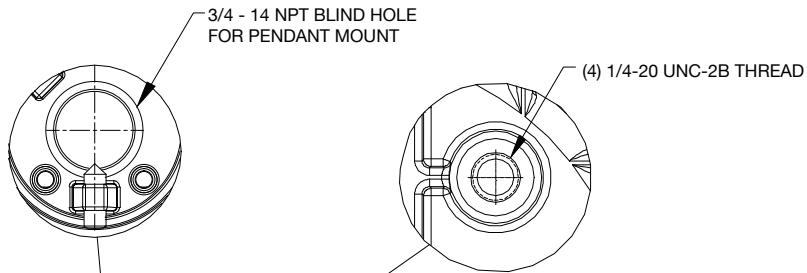

Back View

(1) 3/4 - 14 NPT  
 FOR CABLE ENTRY WITH  
 CLOSE-UP PLUG

IBHL Models

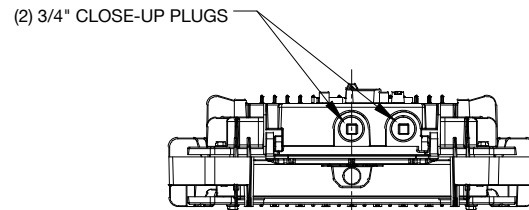

Bottom View

LED/HIGH BAY: NEC/CEC ORDINARY LOCATION



# Industrial Baymaster™ HL LED Luminaire

## High Bay for Ordinary Locations

**NEC/CEC:**  
 Marine outside type (salt water) for USA Only  
 Wet locations  
 Type 3R, 4, 4X  
 IP66/67

### Photometric Data – DATA SHOWN IS ABSOLUTE

**Type V Narrow, Clear Glass 5000K CCT**  
 REPORT NUMBER: IBHLPL1CGNNBU

Luminaire Lumens 24,459

**POLAR CANDELA DISTRIBUTION**

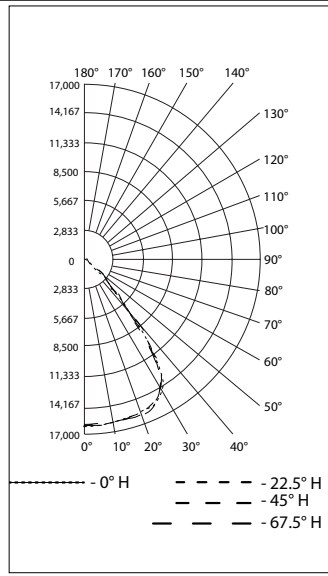

**ISOFOOT CANDLE PLOT**

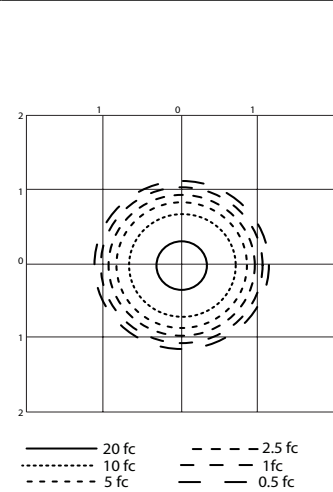

**ZONAL LUMEN SUMMARY**

Zone	Lumens	% Luminaire
0-30	13,267.9	54.3%
0-40	20,732.9	84.8%
0-60	23,891.8	97.7%
60-90	561.6	2.3%
70-100	242.1	1%
90-120	0	0%
0-90	24,453.4	100%
90-180	0	0%
0-180	24,453.4	100%

**LUMENS PER ZONE**

Zone	Lumens	% Total	Zone
0-10	1,538.5	6.3%	90 -100
10-20	4,553.8	18.6%	100 -110
20-30	7,175.6	29.3%	110 -120
30-40	7,465.0	30.5%	120 -130
40-50	2,717.0	11.1%	130 -140
50-60	441.9	1.8%	140 -150
60-70	319.5	1.3%	150 -160
70-80	215.3	0.9%	160 -170
80-90	26.8	0.1%	170 -180

**Type V Narrow, Clear Glass 3000K CCT**

REPORT NUMBER: IBHLPL1WGNBU

Luminaire Lumens 21,648

**POLAR CANDELA DISTRIBUTION**

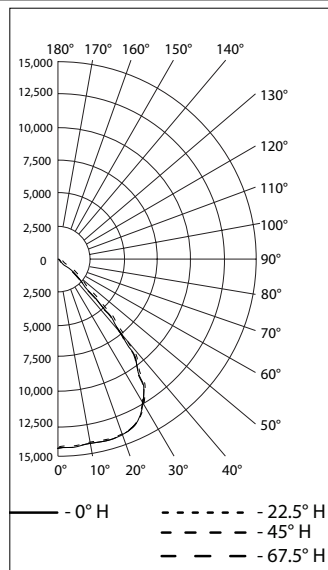

**ISOFOOT CANDLE PLOT**

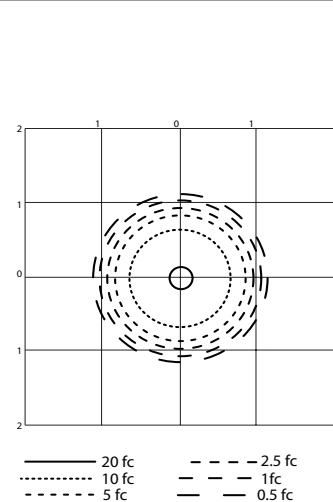

**ZONAL LUMEN SUMMARY**

Zone	Lumens	% Luminaire
0-30	11,658.8	53.9%
0-40	18,259.6	84.4%
0-60	21,173.3	97.8%
60-90	469.0	2.2%
70-100	195.8	0.9%
90-120	0	0%
0-90	21,642.2	100%
90-180	0	0%
0-180	21,642.2	100%

**LUMENS PER ZONE**

Zone	Lumens	% Total	Zone
0-10	1,538.5	6.3%	90-100
10-20	4,553.8	18.6%	100-110
20-30	7,175.6	29.3%	110-120
30-40	7,465.0	30.5%	120-130
40-50	2,717.0	11.1%	130-140
50-60	441.9	1.8%	140-150
60-70	319.5	1.3%	150-160
70-80	215.3	0.9%	160-170
80-90	26.8	0.1%	170-180

LED/HIGH BAY: NEC/CEC ORDINARY LOCATION



# Industrial Baymaster™ HL LED Luminaire

## High Bay for Ordinary Locations

**NEC/CEC:**  
 Marine outside type (salt water) for USA Only  
 Wet locations  
 Type 3R, 4, 4X  
 IP66/67

### Photometric Data — DATA SHOWN IS ABSOLUTE

**Type V Narrow, Clear Glass 5000K CCT**

REPORT NUMBER: IBHLPL2CGNNBU

Luminaire Lumens 30,396

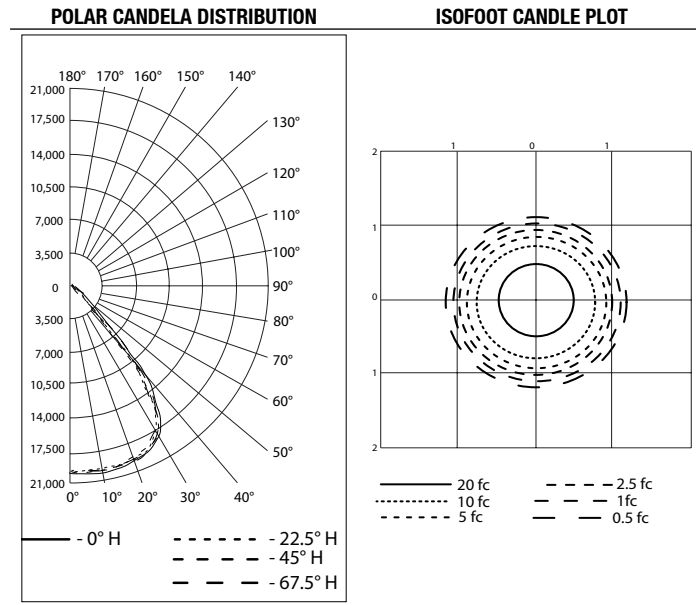

**ZONAL LUMEN SUMMARY**

Zone	Lumens	% Luminaire
0-30	16,453.1	54.1%
0-40	25,742.1	84.7%
0-60	29,699.7	97.7%
60-90	688.8	2.3%
70-100	296.7	1%
90-120	0	0%
0-90	30,388.4	100%
90-180	0	0%
0-180	30,388.4	100%

**LUMENS PER ZONE**

Zone	Lumens	% Total	Zone
0-10	1,909.5	6.3%	90-100
10-20	5,644.4	18.6%	100-110
20-30	8,899.2	29.3%	110-120
30-40	9,289.1	30.6%	120-130
40-50	3,411.2	11.2%	130-140
50-60	546.3	1.8%	140-150
60-70	392.0	1.3%	150-160
70-80	263.9	0.9%	160-170
80-90	32.9	0.1%	170-180

**Type V Narrow, Clear Glass 3000K CCT**

REPORT NUMBER: IBHLPL2WGNNU

Luminaire Lumens 25,785

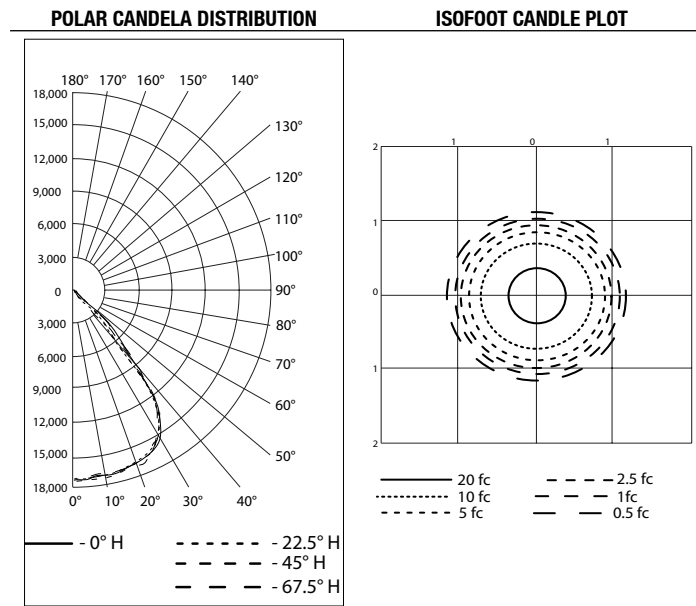

**ZONAL LUMEN SUMMARY**

Zone	Lumens	% Luminaire
0-30	13,938.3	54.1%
0-40	21,797.3	84.6%
0-60	25,219.8	97.8%
60-90	559.0	2.2%
70-100	234.4	0.9%
90-120	0	0%
0-90	25,778.8	100%
90-180	0	0%
0-180	25,778.8	100%

**LUMENS PER ZONE**

Zone	Lumens	% Total	Zone
0-10	1,633.4	6.3%	90-100
10-20	4,795.3	18.6%	100-110
20-30	7,509.5	29.1%	110-120
30-40	7,859.0	30.5%	120-130
40-50	2,974.1	11.5%	130-140
50-60	448.4	1.7%	140-150
60-70	324.5	1.3%	150-160
70-80	208.1	0.8%	160-170
80-90	26.3	0.1%	170-180

LED/HIGH BAY: NEC/CEC ORDINARY LOCATION



# Industrial Baymaster™ HL LED Luminaire

## High Bay for Ordinary Locations

NEC/CEC:  
 Marine outside type (salt water) for USA Only  
 Wet locations  
 Type 3R, 4, 4X  
 IP66/67

### Photometric Data – DATA SHOWN IS ABSOLUTE

Type V Narrow, Clear Glass 5000K CCT

REPORT NUMBER: IBHLPL3CGNNBU

Luminaire Lumens 39,041

#### POLAR CANDELA DISTRIBUTION

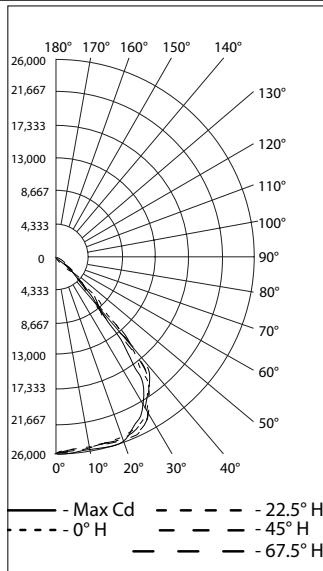

#### ISOFOOT CANDLE PLOT

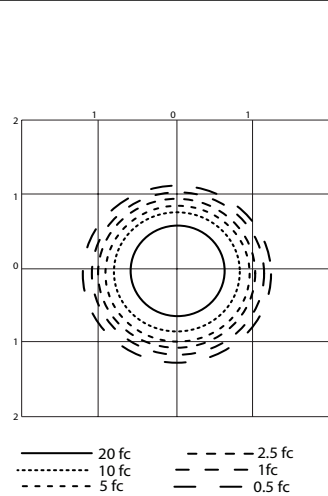

#### FLOOD SUMMARY

Zone	Lumens	% Luminaire
0-30	21,202.1	54.3%
0-40	33,033.7	84.6%
0-60	38,116.4	97.7%
60-90	915.1	2.3%
70-100	393.2	1%
90-120	0	0%
0-90	39,031.5	100%
90-180	0	0%
0-180	39,031.5	100%

#### LUMENS PER ZONE

Zone	Lumens	% Total	Zone
0-10	2,460.1	6.3%	90-100
10-20	7,287.2	18.7%	100-110
20-30	11,454.8	29.3%	110-120
30-40	11,831.6	30.3%	120-130
40-50	4,348.6	11.1%	130-140
50-60	734.2	1.9%	140-150
60-70	521.9	1.3%	150-160
70-80	347.9	0.9%	160-170
80-90	45.3	0.1%	170-180

Type V Narrow, Clear Glass 3000K CCT

REPORT NUMBER: IBHLPL3WGNNU

Luminaire Lumens 33,341

#### POLAR CANDELA DISTRIBUTION

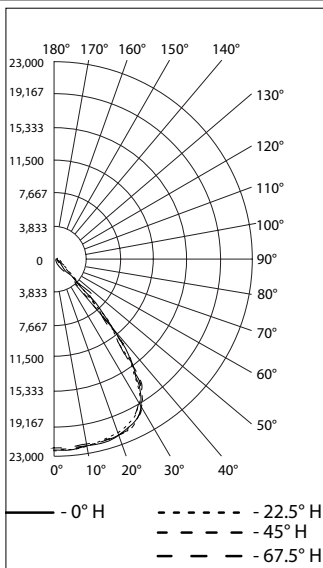

#### ISOFOOT CANDLE PLOT

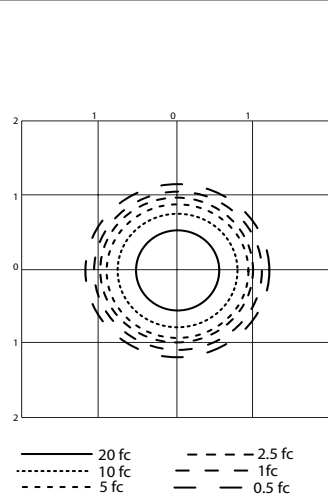

#### ZONAL LUMEN SUMMARY

Zone	Lumens	% Luminaire
0-30	18,117.0	54.4%
0-40	28,265.5	84.8%
0-60	32,605.1	97.8%
60-90	727.8	2.2%
70-100	306.3	0.9%
90-120	0	0%
0-90	33,332.9	100%
90-180	0	0%
0-180	33,332.9	100%

#### LUMENS PER ZONE

Zone	Lumens	% Total	Zone
0-10	2,123.9	6.4%	90-100
10-20	6,237.4	18.7%	100-110
20-30	9,755.7	29.3%	110-120
30-40	10,148.5	30.4%	120-130
40-50	3,760.3	11.3%	130-140
50-60	579.3	1.7%	140-150
60-70	421.5	1.3%	150-160
70-80	272.0	0.8%	160-170
80-90	34.3	0.1%	170-180

LED/HIGH BAY- NEC/CEC ORDINARY LOCATION



# Industrial Baymaster™ HL LED Luminaire

## High Bay for Ordinary Locations

**NEC/CEC:**  
 Marine outside type (salt water) for USA Only  
 Wet locations  
 Type 3R, 4, 4X  
 IP66/67

### Photometric Data — DATA SHOWN IS ABSOLUTE

**Type V Wide, Clear Glass 5000K CCT**

REPORT NUMBER: IBHLPL1CGWNBUB

Luminaire Lumens 20,665

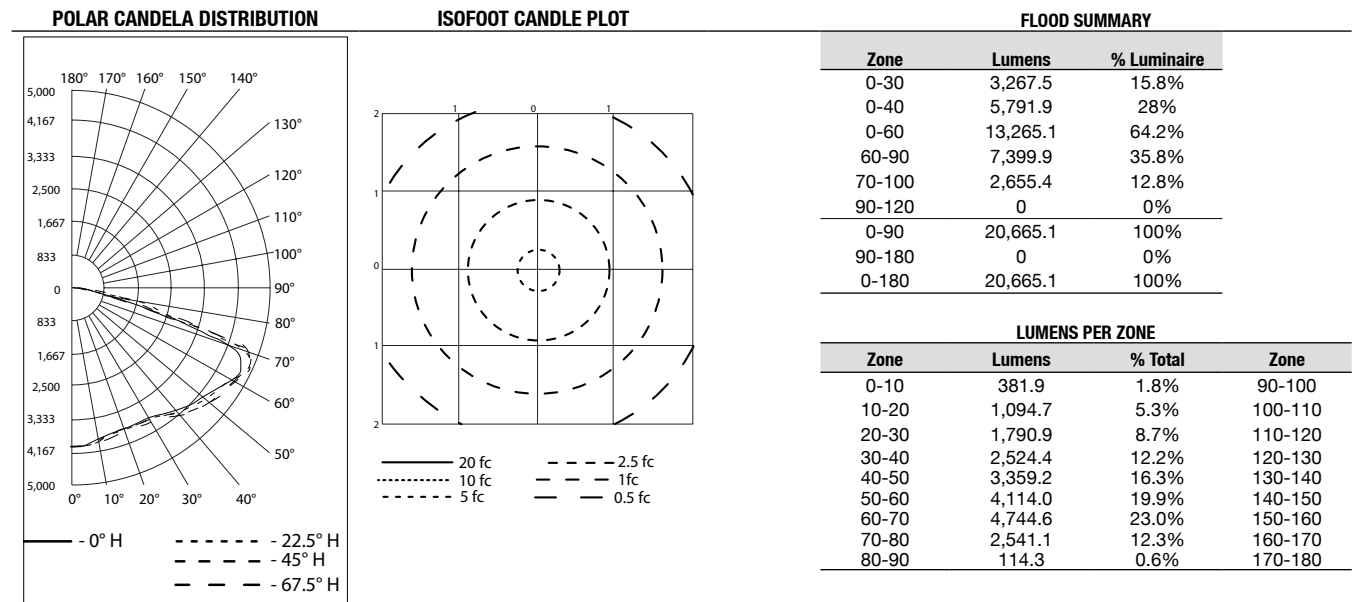

**Type V Wide, Clear Glass 3000K CCT**

REPORT NUMBER: IBHLPL1WGWNBUB

Luminaire Lumens 18,689

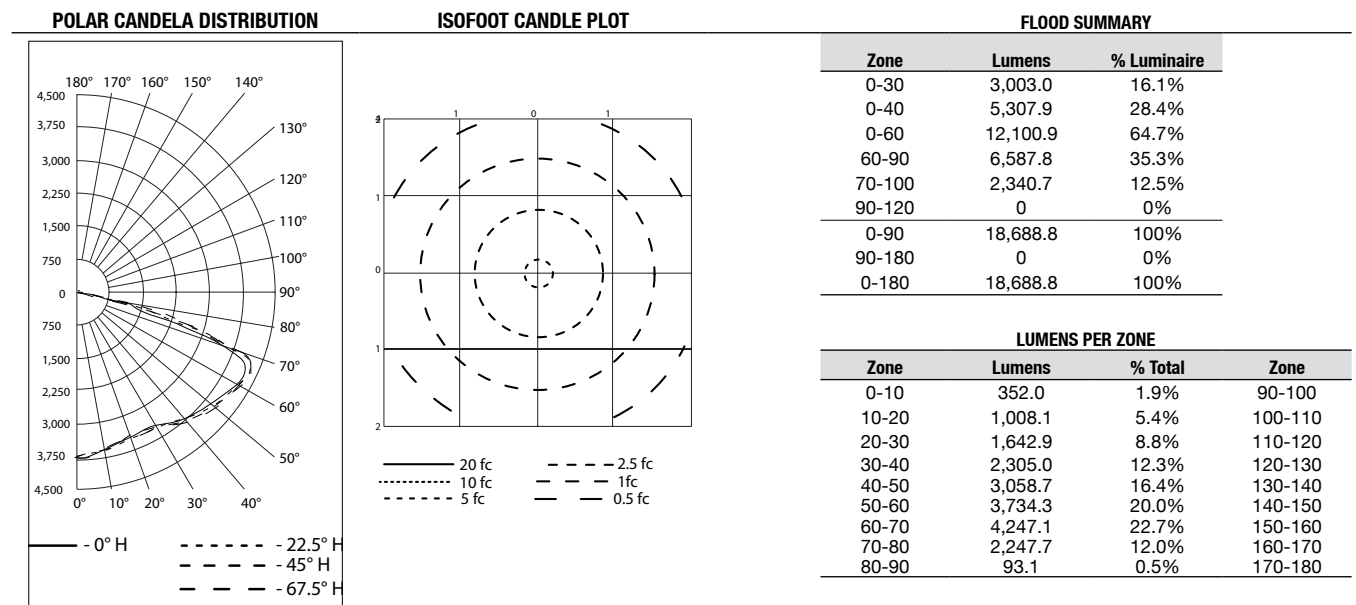

LED/HIGH BAY: NEC/CEC ORDINARY LOCATION



# Industrial Baymaster™ HL LED Luminaire

## High Bay for Ordinary Locations

NEC/CEC:  
 Marine outside type (salt water) for USA Only  
 Wet locations  
 Type 3R, 4, 4X  
 IP66/67

### Photometric Data – DATA SHOWN IS ABSOLUTE

Type V Wide, Clear Glass 5000K CCT  
 REPORT NUMBER: IBHLPL2CGWNBU

Luminaire Lumens 25, 896

#### POLAR CANDELA DISTRIBUTION

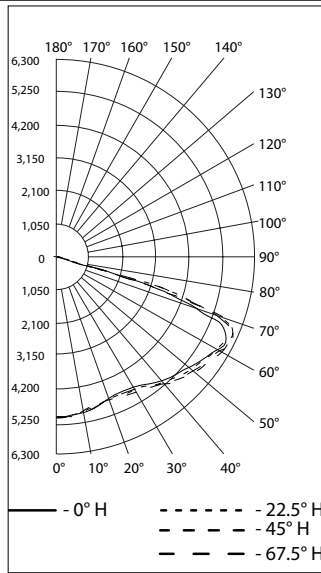

#### ISOFOOT CANDLE PLOT

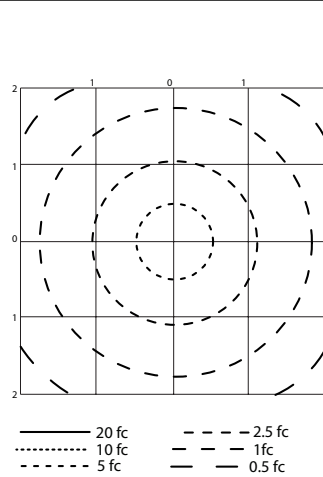

#### FLOOD SUMMARY

Zone	Lumens	% Luminaire
0-30	4,099.3	15.8%
0-40	7,263.6	28%
0-60	16,635.1	64.2%
60-90	9,260.5	35.8%
70-100	3,317.2	12.8%
90-120	0	0%
0-90	25,895.6	100%
90-180	0	0%
0-180	25,895.6	100%

#### LUMENS PER ZONE

Zone	Lumens	% Total	Zone
0-10	478.9	1.8%	90-100
10-20	1,373.3	5.3%	100-110
20-30	2,247.1	8.7%	110-120
30-40	3,164.3	12.2%	120-130
40-50	4,214.3	16.3%	130-140
50-60	5,157.2	19.9%	140-150
60-70	5,943.3	23.0%	150-160
70-80	3,178.9	12.3%	160-170
80-90	138.3	0.5%	170-180

Type V Wide, Clear Glass 3000K CCT  
 REPORT NUMBER: IBHLPL2WGWNBUB

Luminaire Lumens 22,278

#### POLAR CANDELA DISTRIBUTION

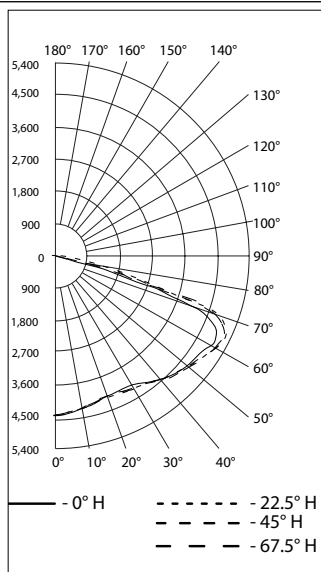

#### ISOFOOT CANDLE PLOT

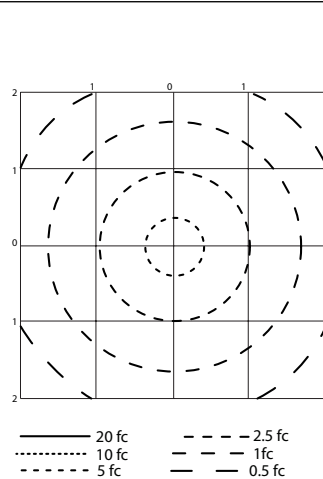

#### FLOOD SUMMARY

Zone	Lumens	% Luminaire
0-30	3,582.7	16.1%
0-40	6,332.7	28.4%
0-60	14,434.3	64.8%
60-90	7,843.9	35.2%
70-100	2,774.1	12.5%
90-120	0	0%
0-90	22,278.2	100%
90-180	0	0%
0-180	22,278.2	100%

#### LUMENS PER ZONE

Zone	Lumens	% Total	Zone
0-10	420.0	1.9%	90-100
10-20	1,202.3	5.4%	100-110
20-30	1,960.4	8.8%	110-120
30-40	2,749.9	12.3%	120-130
40-50	3,650.1	16.4%	130-140
50-60	4,451.5	20.0%	140-150
60-70	5,069.8	22.8%	150-160
70-80	2,669.2	12.0%	160-170
80-90	104.9	0.5%	170-180

LED/HIGH BAY: NEC/CEC ORDINARY LOCATION



# Industrial Baymaster™ HL LED Luminaire

## High Bay for Ordinary Locations

**NEC/CEC:**  
 Marine outside type (salt water) for USA Only  
 Wet locations  
 Type 3R, 4, 4X  
 IP66/67

### Photometric Data — DATA SHOWN IS ABSOLUTE

**Type V Wide, Clear Glass 5000K CCT**

REPORT NUMBER: IBHLPL3CGWNB

Luminaire Lumens 33,374

#### POLAR CANDELA DISTRIBUTION

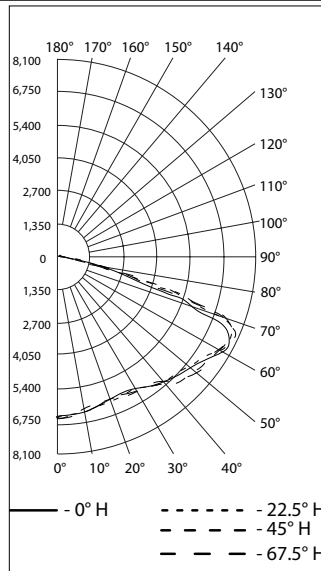

#### ISOFOOT CANDLE PLOT

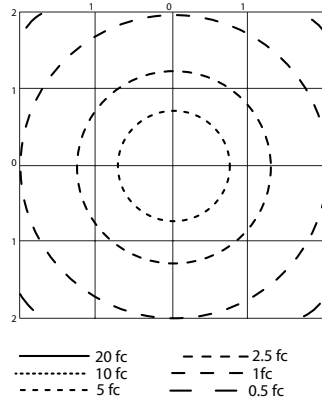

#### FLOOD SUMMARY

Zone	Lumens	% Luminaire
0-30	5,286.5	15.8%
0-40	9,369.3	28.1%
0-60	21,475.2	64.3%
60-90	11,898.9	35.7%
70-100	4,224.4	12.7%
90-120	0	0%
0-90	33,374.1	100%
90-180	0	0%
0-180	33,374.1	100%

#### LUMENS PER ZONE

Zone	Lumens	% Total	Zone
0-10	617.3	1.8%	90-100
10-20	1,771.1	5.3%	100-110
20-30	2,898.1	8.7%	110-120
30-40	4,082.8	12.2%	120-130
40-50	5,443.0	16.3%	130-140
50-60	6,662.9	20.0%	140-150
60-70	7,674.5	23.0%	150-160
70-80	4,065.1	12.2%	160-170
80-90	159.3	0.5%	170-180

**Type V Wide, Clear Glass 3000K CCT**

REPORT NUMBER: IBHLPL3WGWNB

Luminaire Lumens 28,864

#### POLAR CANDELA DISTRIBUTION

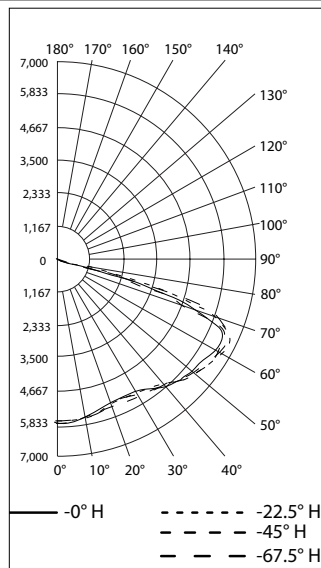

#### ISOFOOT CANDLE PLOT

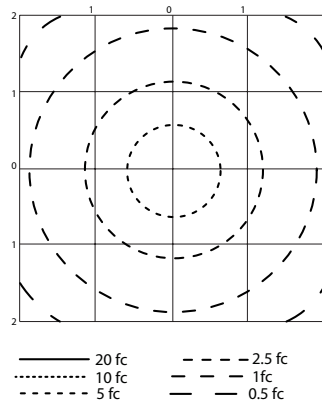

#### FLOOD SUMMARY

Zone	Lumens	% Luminaire
0-30	4,643.3	16.1%
0-40	8,209.1	28.4%
0-60	18,724.5	64.9%
60-90	10,139.9	35.1%
70-100	3,562.1	12.3%
90-120	0	0%
0-90	28,864.4	100%
90-180	0	0%
0-180	28,864.4	100%

#### LUMENS PER ZONE

Zone	Lumens	% Total	Zone
0-10	544.2	1.9%	90-100
10-20	1,558.1	5.4%	100-110
20-30	2,541.0	8.8%	110-120
30-40	3,565.8	12.4%	120-130
40-50	4,737.0	16.4%	130-140
50-60	5,778.4	20.0%	140-150
60-70	6,577.8	22.8%	150-160
70-80	3,431.3	11.9%	160-170
80-90	130.9	0.5%	170-180

LED/HIGH BAY: NEC/CEC ORDINARY LOCATION



# Industrial Baymaster™ HL LED Luminaire

## High Bay for Ordinary Locations

NEC/CEC:  
 Marine outside type (salt water) for USA Only  
 Wet locations  
 Type 3R, 4, 4X  
 IP66/67

### Photometric Data – DATA SHOWN IS ABSOLUTE

Type V Medium, Frosted Glass 5000K CCT

REPORT NUMBER: IBHLPL1CFMNB

Luminaire Lumens 20,801

#### POLAR CANDELA DISTRIBUTION

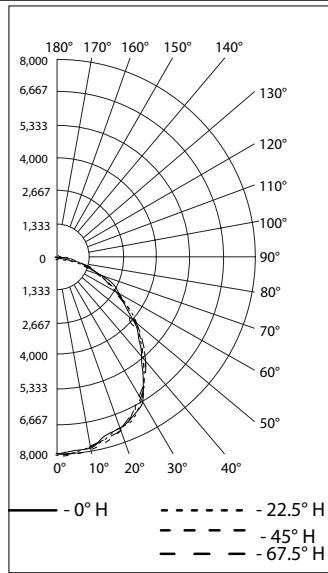

#### ISOFOOT CANDLE PLOT

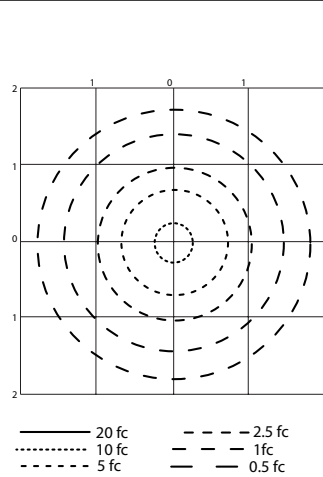

#### FLOOD SUMMARY

Zone	Lumens	% Luminaire
0-30	6,121.0	29.4%
0-40	9,932.9	47.8%
0-60	17,003.6	81.8%
60-90	3,795.4	18.2%
70-100	1,458.3	7%
90-120	0	0%
0-90	20,799.0	100%
90-180	0	0%
0-180	20,799.0	100%

#### LUMENS PER ZONE

Zone	Lumens	% Total	Zone
0-10	749.2	3.6%	90-100
10-20	2,144.9	10.3%	100-110
20-30	3,226.9	15.5%	110-120
30-40	3,811.9	18.3%	120-130
40-50	3,804.1	18.3%	130-140
50-60	3,266.6	15.7%	140-150
60-70	2,337.1	11.2%	150-160
70-80	1,217.2	5.9%	160-170
80-90	241.1	1.2%	170-180

Type V Medium, Clear Glass 5000K CCT

REPORT NUMBER: IBHLPL1CGMNB

Luminaire Lumens 24,352

#### POLAR CANDELA DISTRIBUTION

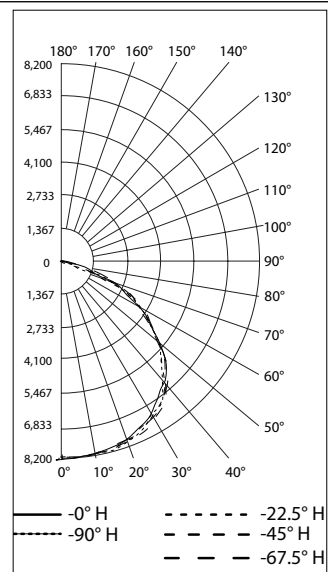

#### ISOFOOT CANDLE PLOT

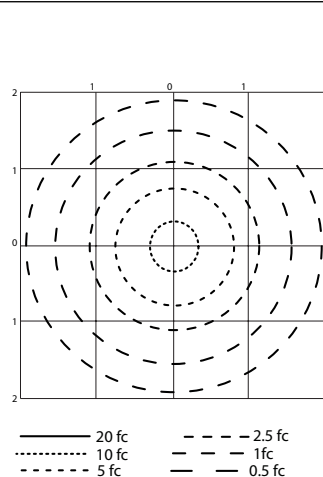

#### FLOOD SUMMARY

Zone	Lumens	% Luminaire
0-30	6,658.2	27.3%
0-40	11,178.5	45.9%
0-60	20,239.3	83.1%
60-90	4,111.0	16.9%
70-100	1,207.1	5%
90-120	0	0%
0-90	24,350.2	100%
90-180	0	0%
0-180	24,350.2	100%

#### LUMENS PER ZONE

Zone	Lumens	% Total	Zone
0-10	773.6	3.2%	90-100
10-20	2,280.5	9.4%	100-110
20-30	3,604.1	14.8%	110-120
30-40	4,520.2	18.6%	120-130
40-50	4,785.8	19.7%	130-140
50-60	4,275.0	17.6%	140-150
60-70	2,903.9	11.9%	150-160
70-80	1,100.3	4.5%	160-170
80-90	106.7	0.4%	170-180

LED/HIGH BAY: NEC/CEC ORDINARY LOCATION



# Industrial Baymaster™ HL LED Luminaire

## High Bay for Ordinary Locations

**NEC/CEC:**  
 Marine outside type (salt water) for USA Only  
 Wet locations  
 Type 3R, 4, 4X  
 IP66/67

### Photometric Data – DATA SHOWN IS ABSOLUTE

**Type V Medium, Frosted Glass 5000K CCT**

REPORT NUMBER: IBHLPL2CFMNB

Luminaire Lumens 25,979

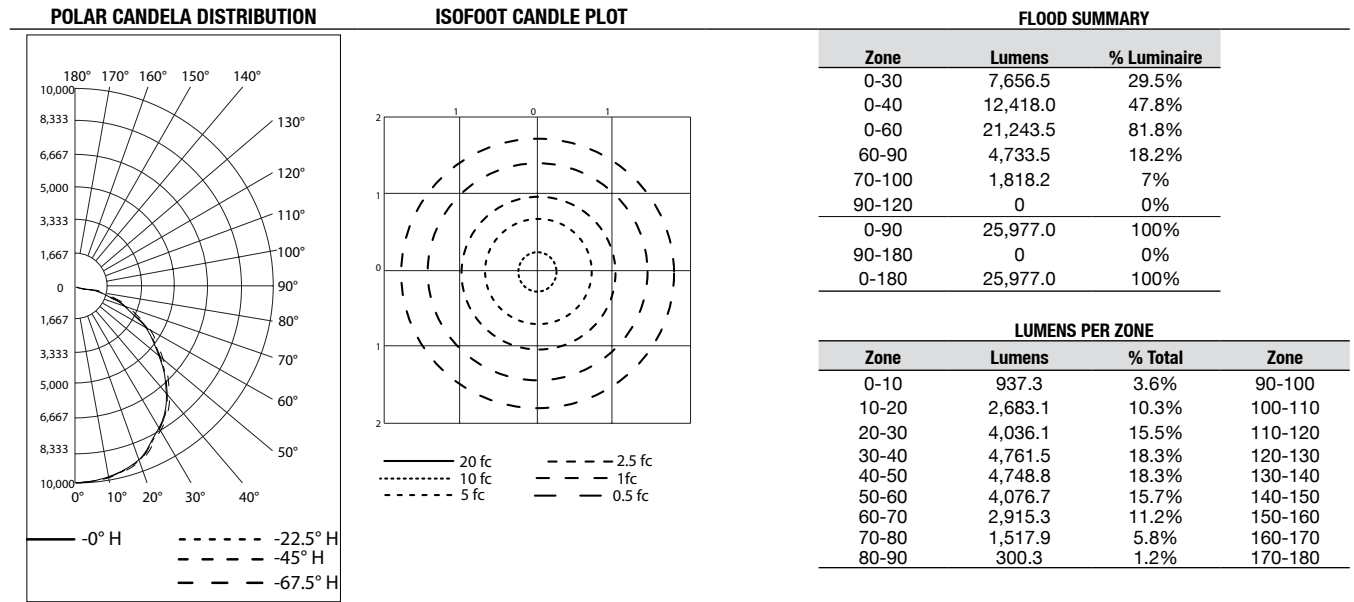

**Type V Medium, Clear Glass 5000K CCT**

REPORT NUMBER: IBHLPL2CGMNB

Luminaire Lumens 30,375

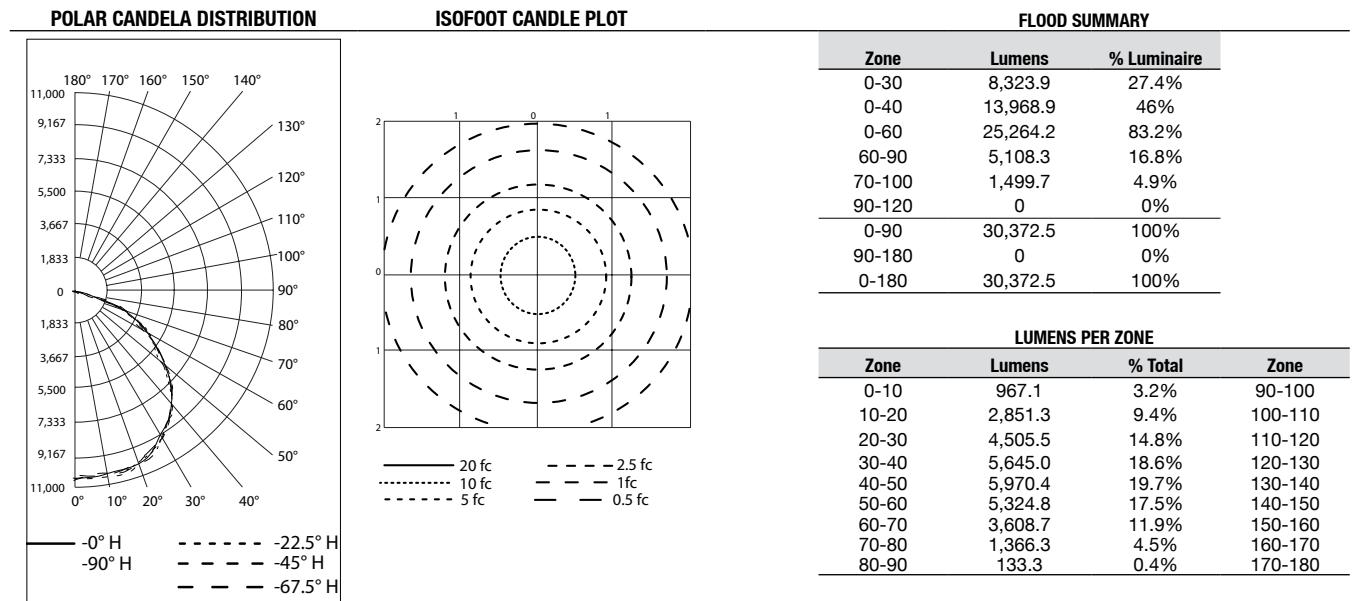

LED/HIGH BAY: NEC/CEC ORDINARY LOCATION



# Industrial Baymaster™ HL LED Luminaire

## High Bay for Ordinary Locations

**NEC/CEC:**

Marine outside type (salt water) for USA Only

Wet locations

Type 3R, 4, 4X

IP66/67

**Photometric Data — DATA SHOWN IS ABSOLUTE**

**Type V, Frosted Glass 5000K CCT**

REPORT NUMBER: **IBHLPL3CFMNB**

Luminaire Lumens 32,107

**POLAR CANDELA DISTRIBUTION**

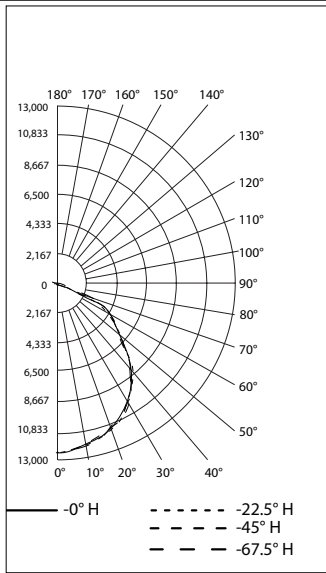

**ISOFOOT CANDLE PLOT**

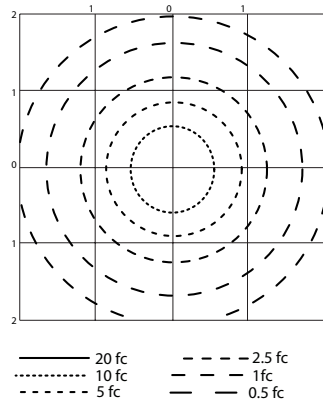

**FLOOD SUMMARY**

Zone	Lumens	% Luminaire
0-30	9,470.7	29.5%
0-40	15,360.8	47.8%
0-60	26,252.9	81.8%
60-90	5,851.6	18.2%
70-100	2,251.6	7%
90-120	0	0%
0-90	32,104.5	100%
90-180	0	0%
0-180	32,104.5	100%

**LUMENS PER ZONE**

Zone	Lumens	% Total	Zone
0-10	1,160.6	3.6%	90-100
10-20	3,319.7	10.3%	100-110
20-30	4,990.5	15.5%	110-120
30-40	5,890.0	18.3%	120-130
40-50	5,863.2	18.3%	130-140
50-60	5,028.9	15.7%	140-150
60-70	3,600.0	11.2%	150-160
70-80	1,879.7	5.9%	160-170
80-90	371.9	1.2%	170-180

**Type V, Clear Glass 5000K CCT**

REPORT NUMBER: **IBHLPL3CGMNB**

Luminaire Lumens 37,574

**POLAR CANDELA DISTRIBUTION**

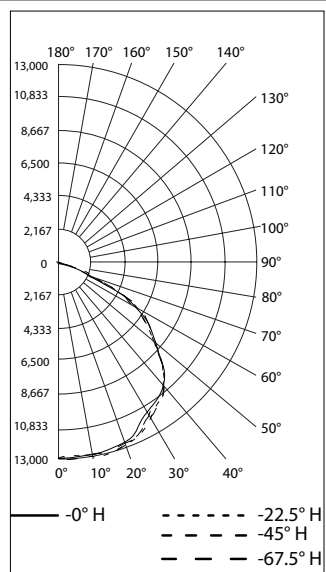

**ISOFOOT CANDLE PLOT**

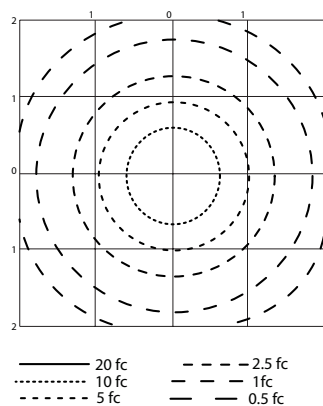

**FLOOD SUMMARY**

Zone	Lumens	% Luminaire
0-30	10,427.6	27.8%
0-40	17,424.5	46.4%
0-60	31,266.2	83.2%
60-90	6,304.9	16.8%
70-100	1,911.4	5.1%
90-120	0	0%
0-90	37,571.2	100%
90-180	0	0%
0-180	37,571.2	100%

**LUMENS PER ZONE**

Zone	Lumens	% Total	Zone
0-10	1,219.3	3.2%	90-100
10-20	3,578.9	9.5%	100-110
20-30	5,629.5	15.0%	110-120
30-40	6,996.9	18.6%	120-130
40-50	7,346.6	19.6%	130-140
50-60	6,495.1	17.3%	140-150
60-70	4,393.6	11.7%	150-160
70-80	1,713.0	4.6%	160-170
80-90	198.3	0.5%	170-180

LED/HIGH BAY: NEC/CEC ORDINARY LOCATION

